



ROCHESTER PUBLIC UTILITIES

PUBLIC WATER SYSTEM CROSS
CONNECTION CONTROL AND
BACKFLOW PREVENTION PROGRAM

Rochester Public Utilities
4000 East River Rd NE
Rochester, Minnesota 55906-2813
Telephone: 507-280-1540
Facsimile: 507-280-1643
[RPU's website](#)

Revised February 23, 2016

TABLE OF CONTENTS

ROCHESTER PUBLIC UTILITIES	1
PUBLIC WATER SYSTEM CROSS CONNECTION CONTROL AND BACKFLOW PREVENTION PROGRAM	1
100 PURPOSE	3
200 AUTHORITY	3
300 RESPONSIBILITY	3
400 DEFINITIONS	4
500 ADMINISTRATION	7
600 REQUIREMENTS	8
700 DEGREE OF HAZARD	10
800 EXISTING BACKFLOW PREVENTER ASSEMBLIES	10
900 PERIODIC TESTING AND MAINTENANCE	11
1000 RECORDS AND REPORTS	11

100 PURPOSE

101 To protect the public potable water supply for the City of Rochester, Minnesota, operated by Rochester Public Utilities (RPU) from the possibility of contamination or pollution. This is accomplished by isolating, within the customer's internal distribution system, such contaminants or pollution sources which could backflow or back-siphon into the public potable water supply.

102 To promote the elimination or control of existing cross-connections, actual or potential, between the customer's potable water system, and the public potable water supply for the City of Rochester, Minnesota. This is being accomplished by containment protection at the water service entrance to a premise.

103 To provide for the maintenance of a continuing Program of cross-connection control which will systematically and effectively prevent the contamination or pollution of the public potable water supply for the City or Rochester, Minnesota.

200 AUTHORITY

201 The Federal Safe Drinking Water Act of 1974, MN Water Supply Rule 4720.0025, and the current Minnesota Plumbing Code.

202 Rochester Public Utilities' Water Service Rules and Regulations, Section 900.

300 RESPONSIBILITY

RPU shall be responsible for the protection of the public potable water supply from contamination or pollution due to backflow or backsiphonage of contaminants or pollutants through the water service connection. If, in the judgment of RPU, or a City of Rochester Building Safety representative, an approved backflow preventer is required, notice in writing, will be given to said Owner to install an approved backflow preventer at the water service entrance immediately upstream or downstream of the RPU water meter on the premises at the Owner's expense. The Owner shall, within sixty (60) days install such approved assembly or assemblies at their own expense, and failure or refusal, or inability on the part of the Owner to install said assembly or assemblies within sixty (60) days, shall constitute a ground for discontinuing water service to the premises until such assembly or assemblies have been properly installed.

400 DEFINITIONS

401 Approved: Accepted by RPU and/or the Rochester Building Safety Plumbing Inspection Division as meeting an applicable specification stated or cited in this regulation, or as suitable for the proposed use.

402 Auxiliary Water Supply: Any water supply, on or available, to the premises other than the RPU provided public water supply.

403 Backflow: The flow of water or other liquids, mixtures or substances, under positive or reduced pressure into the distribution pipes of a potable water supply from any source other than its intended source.

404 Backflow Preventer Assembly: A testable backflow prevention assembly, which inhibits backflow or backsiphonage into the public potable water supply for the City of Rochester, Minnesota. Most commonly categorized as double check valve assembly (DCV), pressure vacuum breaker assembly (PVB), or a reduced pressure zone assembly (RPZ).

404.1 Double Check Valve (DCV): An assembly containing two internally loaded, independently operating, approved check valves, two resilient-seated shutoff valves, and four properly located test cocks. The DCV shall be installed as an assembly as designed and constructed by the manufacturer.

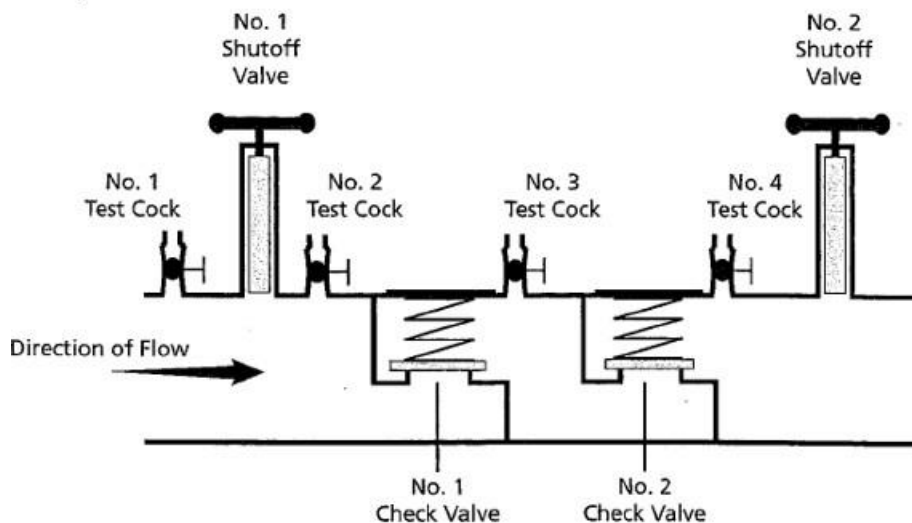

404.2 Pressure Vacuum Breaker (PVB): An assembly containing an independently operating, internally loaded check valve and an independently operating, loaded air-inlet valve located on the discharge side of the check valve. In addition, the PVB assembly shall have an inlet and outlet resilient-seated, fully ported shutoff valve and two properly located resilient-seated test cocks. The PVB shall be installed as an assembly as designed and constructed by the manufacturer.

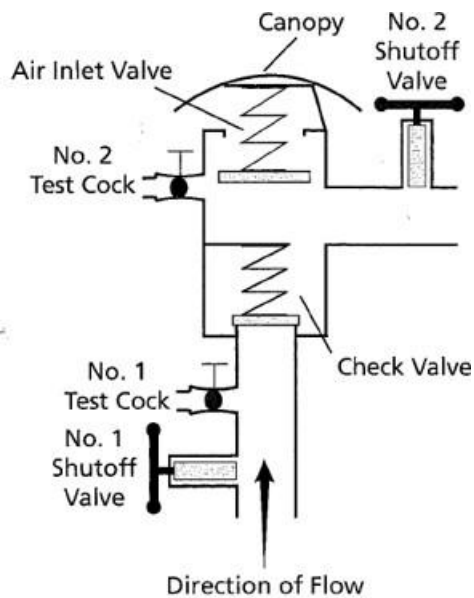

404.3 Reduced Pressure Zone (RPZ) Backflow Preventer: An assembly containing two loaded, independently acting check valves with a hydraulically operating, mechanically independent pressure-differential relief valve located between the check valves below the first check valve. The check valves and the relief valve shall be located between two tightly closing, fully ported, resilient-seated shutoff valves. The RPZ shall have four properly located resilient-seated test cocks. The RPZ shall be installed as an assembly as designed and

constructed by the manufacturer.

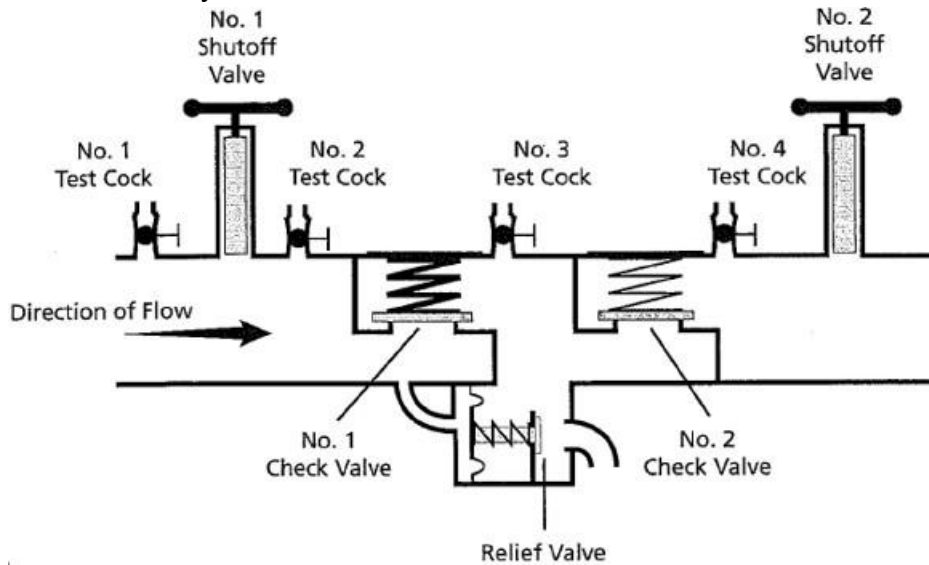

404.4 Spill Resistant Pressure Vacuum Breaker (SVB) Assembly: An assembly containing an independently operating internally loaded check valve and independently operating loaded air inlet valve located on the discharge side of the check valve. The assembly is to be equipped with a properly located resilient seated test cock, a properly located bleed / vent port, and tightly closing resilient seated shutoff valves attached at each end of the assembly. This assembly is designed to protect against a non-health hazard or a health hazard

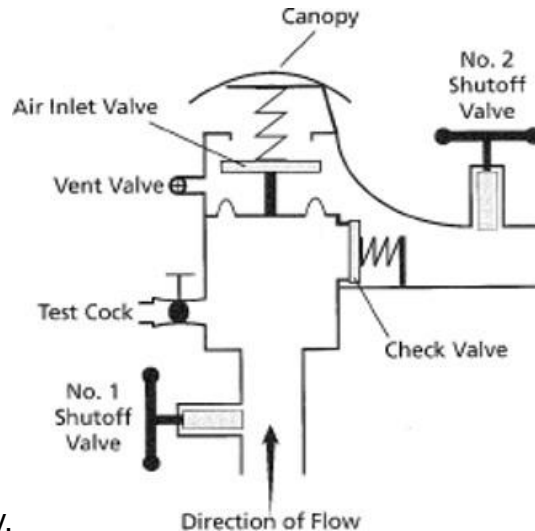

under a backsiphonage condition only.

405 Backpressure: A condition in which the building plumbing system pressure is greater than the supplier's system pressure.

406 Backsiphonage: The flow of water or other liquids, mixtures or substances into the distribution pipes of a potable water supply system from any source other than its intended source caused by the sudden reduction of pressure in the potable water supply system.

407 Containment: A method of backflow prevention which requires backflow prevention at the water service entrance to the premise(s) immediately downstream of the RPU water meter.

408 Contaminant: A substance that impairs the quality of the water to a degree that it creates a serious health hazard to the public leading to poisoning or the spread of disease.

409 Cross Connection: Any connection between the public water supply and a source of contamination or pollution.

410 Isolation: A method of backflow prevention in which a backflow preventer is located at the source or "point of use" of the potential hazard to correct a cross connection at a location within the owner's building or facility.

411 Rochester Public Utilities (RPU): Water purveyor for the City of Rochester, Minnesota.

412 Owner: Any person, who has legal title to, or license to operate or inhabit a property.

413 Person: Any individual, partnership, company, public or private corporation, political subdivision or agency of the State Department, agency or instrumentality of the United States or any other legal entity.

414 Pollutant: A foreign substance that, if introduces into the public water system, will degrade its quality so as to constitute a moderate hazard, or impair the usefulness or quality of the water to a degree which does not create an actual hazard to the public health but which does adversely and unreasonably effect such water for domestic use.

415 Water Service Entrance: That point in the Owner's water system beyond the sanitary control of RPU; generally considered to be the outlet end of the water meter and always before any unprotected branch.

500 ADMINISTRATION

501 RPU will operate a Cross Connection Control and Backflow Prevention Program, to include the keeping of necessary records, which fulfills the requirements of

the RPU Public Water System Cross-Connection Control and Backflow Prevention Program.

502 The Owner shall allow access to their premise/s served by RPU provided, public water supply for evaluation of possible cross-connections by RPU, or a RPU designated representative, per RPU Water Service Rules and Regulations, Section 900, and shall follow the provisions of the RPU Public Water System Cross Connection Control and Backflow Prevention Program.

503 If RPU or a City of Rochester Building Safety representative requires the public water supply to be protected by containment, the Owner shall provide the proper backflow prevention at the water service entrance to the premise/s immediately downstream of the RPU water meter and shall be responsible for water quality beyond the outlet end of the backflow preventer assembly. The Owner shall utilize point of use protection per current Minnesota Plumbing Code for this purpose. RPU may utilize public health officials, City of Rochester Building Safety representatives, or other RPU designated representatives, to assist them in the evaluation of facilities and to assist in the selection of proper backflow preventer assembly(s) and to ensure the assemblies are properly installed.

600 REQUIREMENTS

601 RPU

601.1 For new Commercial or Industrial installations, the City of Rochester Building Safety Department Plumbing Inspection Division will provide on-site evaluation and inspection of plans in order to determine the type of backflow protection that will be required. As designated by the City of Rochester Building Safety Plumbing Inspection Division, all new commercial or industrial facilities will require a Double Check Valve (DCV) assembly or Reduced Pressure Zone (RPZ) backflow preventer assembly and shall be located at the water service entrance to the premise(s) immediately upstream or downstream of the RPU water meter.

601.2 For Commercial or Industrial premises existing prior to the start of this program, RPU, or a RPU designated representative, will perform an evaluation of potential backflow into the public water system and inform the Owner by letter of any corrective action deemed necessary, the method of achieving the correction, and the time allowed for the correction to be made. Ordinarily, sixty (60) days will be allowed; however, this time period may be shortened or lengthened depending upon the degree of hazard involved.

601.3 RPU shall inform the Owner, by letter, of any cross-connection violation. The Owner will have sixty (60) days to correct the violation. If the violation has not been corrected after sixty (60) days, RPU may terminate water service to the

premise. In the event the Owner informs RPU of extenuating circumstances as to why the correction of the violation has not been made, a time extension may be granted by RPU, but in no case will exceed an additional thirty (30) days. If RPU determines at any time that a serious threat to the public health exists, the water service may be terminated immediately.

601.4 For any Residential or Commercial irrigation system, a Pressure Vacuum Breaker (PVB) or Reduced Pressure Zone (RPZ) backflow preventer assembly shall be installed immediately upstream of the irrigation system.

601.5 Any cross connection shall be eliminated unless protected by an approved backflow preventer assembly which shall be regularly tested as required by this program to ensure satisfactory operation.

601.6 RPU will send a notice of violation when the required backflow preventer assembly test is thirty (30) days past due. RPU will send a final notice of violation when the test is sixty (60) days past due. After the final notice, the Owner will have thirty (30) days to become compliant or face possible termination of water service to their premise and may be subject to a reconnection charge. In the event the Owner informs RPU of extenuating circumstances as to why the test has not been made, a time extension may be granted by RPU, but in no case will exceed an additional thirty (30) days.

602 Owner

602.1 The Owner shall be responsible for the elimination or protection of all cross-connections on their premises.

602.2 The Owner after having been informed by letter from RPU, shall at their expense, install, maintain, and test, or have tested, any and all backflow preventer assemblies on their premises.

602.3 The Owner shall correct any malfunction of the backflow preventer assembly.

602.4 The Owner shall inform RPU of any proposed, existing, or modified cross connections of which the Owner is aware.

602.5 The Owner shall not install a bypass around any backflow preventer assembly unless there is a backflow preventer assembly of the same type on the bypass. Owners who cannot shut down operation for testing of the backflow preventer assembly(s) must supply additional backflow prevention as necessary to allow testing to take place.

602.6 The Owner shall install backflow preventers in a manner approved by the current Minnesota Plumbing Code and shall install only backflow preventers approved by the current Minnesota Plumbing Code.

602.7 Any Residential or Commercial Owner having a private well or other private water source shall not be connected to any RPU residential or commercial customer house piping by RPU Rules and Regulations, Section 902.1. Any Industrial Premises/Facility also served by a private well shall install a Reduced Pressure Zone (RPZ) Backflow Preventer assembly at the Owner's cost at the public water supply entrance immediately downstream from the RPU water meter per RPU Rules and Regulations, Section 902.2.

602.8 The Owner shall be responsible for the payment of all fees for permits, testing, repairs, and additional required retesting in cases where the backflow preventer assembly fails to operate correctly.

700 DEGREE OF HAZARD

RPU recognizes the threat to the public water system arising from cross-connections. All hazards will be classified by degree of hazard and may require the installation of an approved backflow preventer assembly. RPU may permit a cross connection within the public water supply system if it is considered necessary and cannot be eliminated and is properly protected by an approved backflow preventer assembly.

701 High Hazard: A cross connection or potential cross connection involving any substance that could, if introduced into the potable water supply, cause death or illness, spread disease, or have a high probability of causing such effects.

702 Low Hazard: A cross connection or potential cross connection involving any substance that generally would not pose a health hazard but would constitute a nuisance or be aesthetically objectionable if introduced into the potable water supply.

For the purposes of this program, all Commercial Premises/Facilities not deemed High Hazard, shall be considered Low Hazard.

800 EXISTING BACKFLOW PREVENTER ASSEMBLIES

Any existing backflow preventer assembly shall be allowed to continue in service until or unless the degree of hazard is such as to supersede the effectiveness of the present backflow preventer assembly or result in an unreasonable risk to the public health. If the Owner of a premise wishes to remove an existing backflow preventer assembly from service, prior approval must be obtained from the City of Rochester Building Safety Department Plumbing Inspection Division before doing so.

900 PERIODIC TESTING AND MAINTENANCE

901 All testable backflow preventer assemblies, regardless of the install date, shall be tested at intervals not to exceed twelve (12) months from the date of the previous test date by an American Society of Sanitary Engineers (ASSE) certified backflow preventer tester and shall be submitted to RPU no more than thirty (30) days after the test date. Any backflow repair needs to be completed by a Licensed Plumber.

902 The required testing and/or repair will be done at the Owner's expense.

903 Any backflow preventer assembly which fails during a periodic test shall be immediately repaired or replaced. When repairs are necessary, upon completion of the repair the backflow preventer assembly will be retested at the owner's expense to ensure correct operation. Parallel installation of two (2) backflow preventer assemblies is an effective means for the Owner to ensure uninterrupted water service during testing or repair of the assembly and is strongly recommended when the owner desires such continuity.

904 RPU may require more frequent backflow preventer assembly testing than specified in 901, 902, or 901 above, in cases where there is a history of test failures and where RPU feels that due to the degree of hazard involved, additional testing is warranted. Cost of the additional tests will be the responsibility of the Owner.

1000 RECORDS AND REPORTS

1001 Records: RPU will initiate and maintain master files on all customer containment backflow preventer assemblies and tests required by this program.

1002 Private Records: RPU will initiate and maintain master files on all customer private isolation "point of use" backflow preventer assemblies as required by the current Minnesota Plumbing Code.